

A Comprehensive Review of Fault Detection & Diagnosis in Photovoltaic Systems

Pramod Sonawane*, Pranjali Jog**, Suvarna Shete***

Dept. of Electronics & Telecommunication, Pimpri Chinchwad College of Engineering, Pune, India

Dept. of First year Engineering, Pimpri Chinchwad College of Engineering, Pune, India

Dept. of First year Engineering, Pimpri Chinchwad College of Engineering, Pune, India

Corresponding Author: Pramod Sonawane

Abstract: With rapid growth of photovoltaic (PV) market throughout the world, fault detection & diagnosis in PV system got the equal importance. Early detection of fault will be useful in order to increase the efficiency, the result of measurement & life of photovoltaic system. If these PV faults not detected & corrected earlier it will seriously affect the energy output of plant. This monitoring & fault detection can be done on site or distantly. Apart from this, few faults like ground faults, Arc Faults, Line to line faults, hot spots may create a risk of fire. In the last few years several techniques have been proposed by the researchers for PV fault detection & diagnosis. In this paper, important faults in Photovoltaics are addressed in details. Also different techniques used for fault diagnosis in PV system proposed in literature are reviewed and analysed to mention their dissimilarity, advantages and disadvantages. Different simulation models for photovoltaic cell are also discussed in brief.

Keywords: photovoltaic, fault detection, simulation models, Partial shading, PV system, Fault diagnosis,

Date of Submission: 25-06-2019

Date of acceptance: 12-07-2019

I. Introduction

From the last few years the use of solar power has been increased rapidly. India is standing at third position in world in terms of solar installation while china & USA stays at first & second position respectively [1]. The advancement in technology & easy availability of solar panels has reduced the overall cost of photovoltaic system significantly. Now a day's solar systems can be found at every other place. The growth in photovoltaic has been triggered by the government policies by providing subsidies to install PV system. It is easier to install the photovoltaic system than to maintain it. There are so many factors, which affect the performance of PV system. As per the survey done by [2], annually the different faults in photovoltaic system reduces the power output by 19%. So the Fault diagnosis & detection plays crucial role in the maintenance of photovoltaic system.

The real time fault monitoring systems are important for controlling & performing fault detection in PV plants. There are so many algorithms recently proposed to perform a real time monitoring of photovoltaic systems. These faults diagnosis methods are classified into three main categories:

- 1) By using visual perception method
- 2) Thermal method
- 3) Electrical methods

The electrical method consists PV cell modelling & simulation [3-6], Electrical signal approach i.e. the Maximum power point tracking method, time domain reflectometry etc. The other category of predictive model approach discussed in [2, 7-9]. In this predictive method the fault can be detected by considering the difference between simulated output & actual output. Few algorithm uses the statistical approach while few methods are based on artificial intelligence approach such as neural network[10-13], learning method, Fuzzy logic[14-16], Bayesian belief network[17], combinational Neuro fuzzy logic, extension theory [18] etc.

This paper is organized as follows: section 2 gives the brief explanation about the basics of PV cell. Section 3 explains the different modelling techniques can be used for photovoltaic cells, Section 4 presents the different failures in photovoltaic system & section 5 provides details about different algorithms & techniques used for fault detection & diagnosis.

II. Basics of Photovoltaic Cell

Photovoltaic cell is equivalent of a small battery with some photocurrent I_p & also equivalent with simple PN junction diode wherein if light or photons falls on junction it produce current. The amount of current is directly proportional to light intensity. In any photovoltaic cell the upper layer is of basically N type

semiconductor & lower layer is made up of P type semiconductor. The metallic contacts are present on both sides of PV cells. The region between both the semiconductors is known as depletion region or active region. This region mainly consists positive & negative immobile ions. When the light falls on the ions they are converted into mobile charge carriers i.e. electron & holes & in this way photocurrent I_p produces. Types of PV cell are basically consists mono crystalline, polycrystalline & thin film cell. The material used for the construction of PV cell is made up of silicon due to large band gap energy. The efficiency of solar cell is the ratio of output power to the Input power. Output power the product of V_m & I_m i.e. the operating points of PV characteristics. Input power is calculated from the product of solar insolation & area of PV cell. The solar insolation can be measured in W/m^2 . We can study the working of solar cell by plotting the basic curve between terminal current & terminal voltage. In these characteristic three important parameters can be considered such as maximum power point, Short circuit current & open circuit voltage. No solar cell is ideal, so two resistances are included along with diode & photocurrent & they are series resistance R_s & Shunt resistance R_{sh} . R_s basically represents the voltage losses along the cell & R_{sh} represents the path to remove the effect of leakage current. Hence after the introduction of these resistances the ideal PV cell becomes a practical PV cell.

III. Modeling of Photovoltaic Cell

Different softwares can be used for the simulation of PV cell such as Pspice, LTspice, and Simulink from Matlab or coding in Matlab. Specific solar related customize softwares can also be used for simulation of PV systems.

3.1 Single diode equivalent model

Many authors used this model to simulate a PV system. As discussed earlier photovoltaic cell is a simple PN junction diode connected in parallel with a current source i.e. photocurrent. The current flowing through the output terminal is calculated by a simple equation.

$$I_p = I_D + I_{sh} + I \quad (1)$$

$$I = I_p - I_D - (V + IR_s)/R_{sh} \quad (2)$$

Where I_p is photocurrent & I_D is the forward current flowing through the Diode. The diode current flowing through the diode can be calculated as

$$I_D = I_0 \left[e^{\left(\frac{V+R_s I}{nV_t}\right)} - 1 \right] \quad (3)$$

Where,

$$V_t = \frac{T}{11600}$$

n is the ideality factor, for Si $n=1.5$

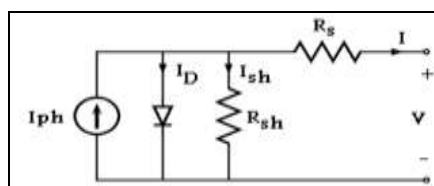

Fig. 1 Single diode equivalent model [3]

3.2 Five parameter Model of PV Cell (used in between the period of 2010-2013)

The terminal current flowing through a single photovoltaic cell can be calculated using following equation & that is known as a five parameter equivalent model of PV cell [19].

$$I = I_{pH} - I_0 \left[e^{\left(\frac{V+R_s I}{nV_t}\right)} - 1 \right] - \left(\frac{V+R_s I}{R_{sh}}\right) \quad (4)$$

In above equation I_0 is known as reverse saturation current flowing through the diode. R_s & R_{sh} are the non ideality resistances.

3.3 Neuro Fuzzy System Based model

In this method different conditions are taking into account such as normal & faulty conditions. The parameters are set at different whether conditions such as temperature, irradiance etc. The comparison can be done with set parameters & threshold values, based on those certain conclusions can be drawn [16]

3.4 Single equation model of PV Cell [8]

Platon develop a single equation which can represent the entire PV module & which gives a simulated output AC Power.

It uses the solar irradiance & PV module temperature as input.

$$P_{ac} = G(\alpha_1 + \alpha_2 G + \alpha_3 \log(G))(1 + \alpha_4 (T_m - 25)) \tag{5}$$

Where, P_{ac} is output power in terms of watt,
 G represents solar irradiance of the module in terms of W/m^2 ,
 T_m is the module temperature ($^{\circ}C$) and $\alpha_1, \alpha_2, \alpha_3$, and α_4 are coefficients calculated.

3.5 Two diode equivalent Model

This used recently by [20] for the simulation of PV system shown in fig.2. This model for photovoltaic cell found more accurate than single diode model. Here one more diode is taken into parallel to remove the recombination effect of diode. It is also proved that better IV characteristics are obtained at lower irradiance & lower temperatures.

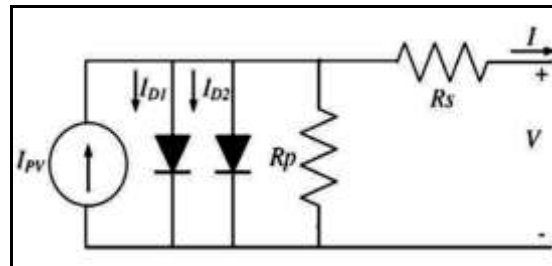

Fig. 2 Two diode equivalent model [20]

IV. Faults in Photovoltaics

PV faults may either electrical faults, faults due to environmental conditions or physical faults. Electrical faults will consists Array faults, Open circuits faults, Line-line faults, Intra String Line-line faults, Line-ground faults, MPPT Failure, Converter switch fault, Battery Bank fault, Hot spots etc. Faults due to environmental constraints consists partial or permanent shading. Physical faults may consists Panel faults, Internal damages in PV cells & bypass diodes, abnormal surface temperature, Cracks in PV panels, broken panels & degradations etc.

The faults in PV system may occur at DC side or AC side. The faults occurred in AC side are easy to detect & locate as compare to DC side using some protection circuits [49-51].

In this section the detailed explanation & analysis is given about all faults occurred in different stages of photovoltaic system, their reasons for occurrence, challenges & how to overcome those.

4.1 Different faults occurred in PV system

1) Ground fault: [52-54,56]

In PV systems all non-current carrying parts or metals are connected to a common ground to prevent electrical shock to the customer or user. Due to some problems or accidents when these parts are comes in contact with current carrying conductors then a huge amount of current flows through the non-current carrying conductors or metals, which create shock to the user. This fault is known as ground fault.

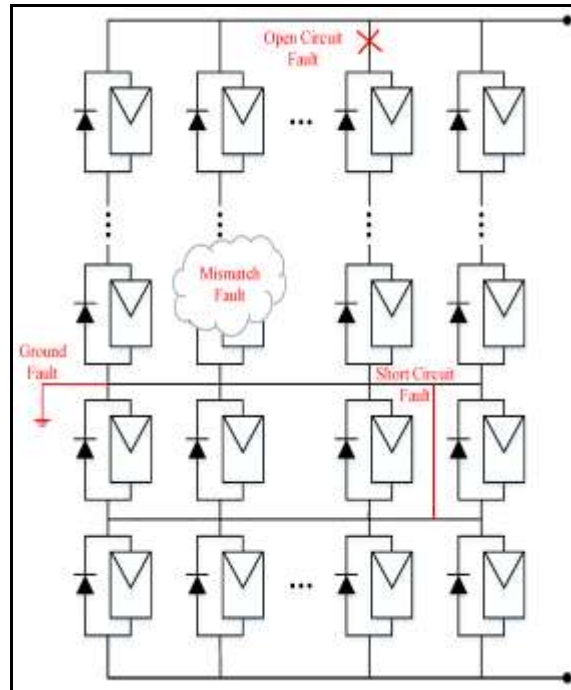

Fig. 3 PV system with ground fault [56]

The ground faults occur in first PV string due to short circuit or some accident.

2) Line to Line faults: [54]

The short circuit occurred between to different points located at different voltages due to some accident is known as line to line fault. The percentage occurrence of this fault in PV array is less but the severity level is very high. These faults are slightly difficult to locate in a particular fault diagnosis method.[57] These faults may be of two types. One may occur between intra string & other is between cross strings.

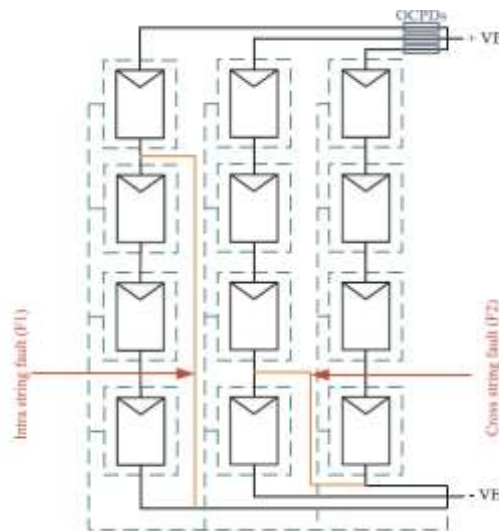

Fig.4 Types of Line to line fault

The line to line faults create severe changes in IV characteristics of PV module.

3) Arc Faults: [58]

In Arc fault high temperature plasma is released, which may cause a PV panel burning. Due to increase in a temperature the combustible material of array is exposed to the Arc. Arc causes air to ionize & plasma gets discharged. The temperature melts the metals & polymer burns. Arc fault is generally classified into two types. 1) Series Arc fault 2) Parallel Arc fault [54]

Series arc fault occurs due to disconnection between conductors & parallel faults occur due to electrical discharge between conductors at different voltages. The protection device Arc fault circuit interrupter is generally kept at 80D dc.

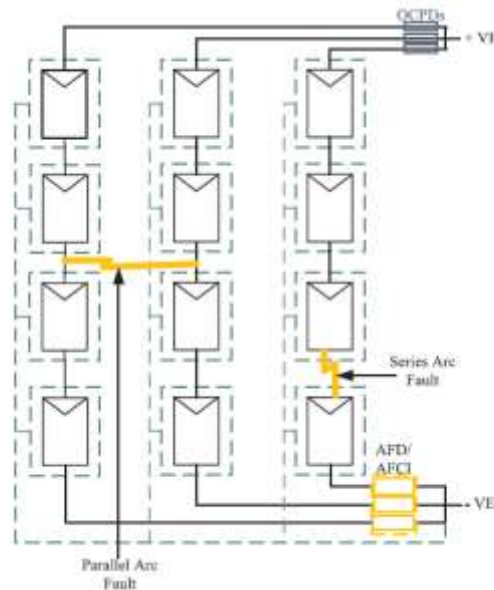

Fig.5 Types of Arc faults in photovoltaic array [54]

4) Shading effect or Fault

When the shadow of neighbouring trees, towers, buildings falls on the photovoltaic panels, the output power decreases significantly .these kind of faults are known as shading. Shading effect is very common & important problem for PV systems. Along with decrease in the output power shading also leads to another fault i.e. hot spot.

fig. 6 shows that due to shading the output power of specific cells is reduced significantly from 1000W/m² to 500W/m², for few cells it reduced upto 300W/m².[54,55]

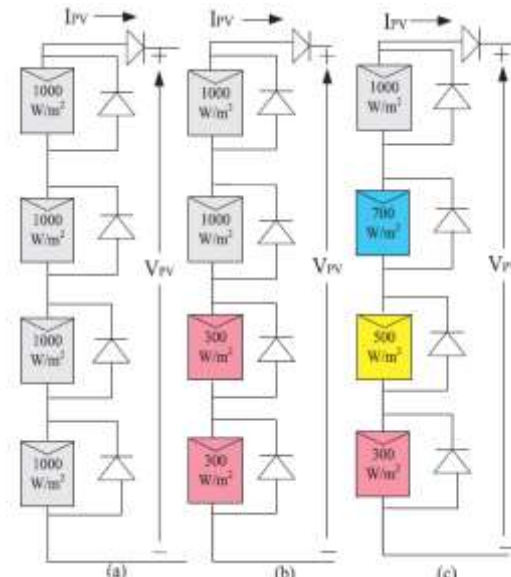

Fig. 6 Effect of shading fault [55]

5) Hot spot fault: [59, 55]

When the IV characteristics of cells in a module are different or varies due to multiple reasons, hot spot fault will occurs. The mismatch in IV characteristics of cell is due to fault in manufacturing process, dust accumulation, ageing effect, module degradation, soiling etc. the mismatch in a characteristics may occurs due to partial shading. Generally the hot spot occurs in a cell or a group of cells, when instead of acting as a

power source, they behaves as power source .i.e. the PV cell acts as a negative voltage source, if this phenomenon continues for a long time hot spot occurs. & the affected cell damages. Infrared thermography is a very popular method to detect hotspot.



Fig. 7 Hot spot observed on damaged cell

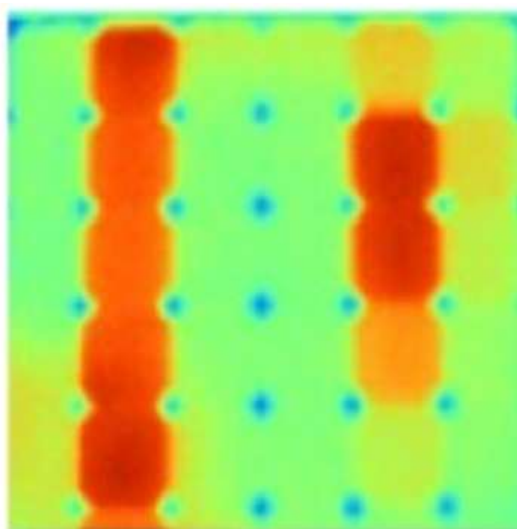

Fig. 8 Hot spot detection using Infrared thermography [59]

6) Bypass & blocking diode fault [61,55]

A very careful selection of bypass & blocking diode is very important for any photovoltaic module. Bypass diode is generally used against the reverse voltage protection or when a PV cell acts as a power dissipater instead of power source. A fault associated with this diode is known as short circuited diode fault. While the blocking diode is used the protection against reverse flowing current through the PV cell & the fault associated with these diodes are known as open circuited diode fault. Bypass & blocking diode play very crucial role while designing a particular PV system. When a PV module came across partial shading for a large amount of time then these faults will occurs.

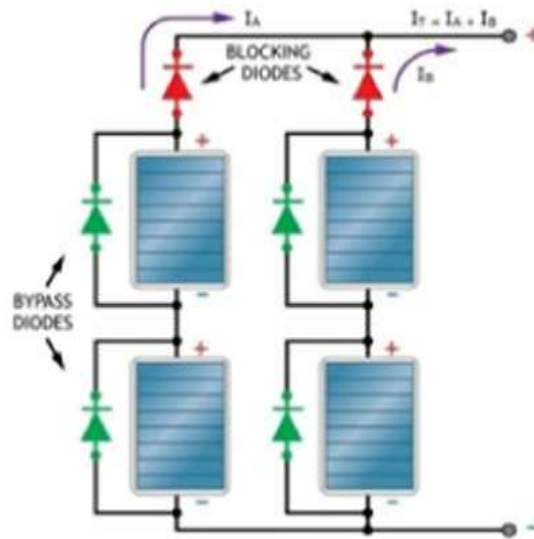

Fig.8 location of Bypass & blocking diodes [55]

7) Junction box fault: [60]

Proper functioning & working of Junction box is very important in any photovoltaic system at on-field. As per [60, 54-55] 85% of faults occurs at the time of system installations & remaining 15% occurs by junction box manufacturers. The main cause of junction box failure is EOS i.e. energy loss stress from system. Other reasons are repairing work of cables on field during installations. Cables without welding & ribbon un proper insert inside junction box may also cause failure of junction box. Improper rework connection during installation is also one the cause of junction box failure.



Fig.9 Junction box

4.2 Analysis of different faults located in PV system

Table 1. PV faults & its cause

Sr.No.	Name of fault	location	Reason of occurrence
1	Line to line fault	This fault basically occurs in PV array/Module	Due to accidental short circuit between two point located at varied potential.
2	Ground fault	PV array/PV module	1)happens due to insulation removal of cables/ conductors 2) Accidental short circuit between ground & conductors
3	Arc Fault	PV array	Due to very high temp the plasma gets discharges & array may burn.
4	Shading effect or fault	PV Panels or PV Module	Due to shadow of neighbouring buildings, towers, big trees falls on PV panels
5	Hot Spots	PV cells or PV modules	may occurs due to high resistance, degradation of cells, or

			may be due mismatch of cells. Partial shadowing
6	PV module fault	PV module	may occurs due to glass breakage, disconnection or wrong connection
7	Bypass diode fault	Bypass diode on PV module	May occurs due to overheating
8	Blocking diode fault	blocking diode	May occurs due to overheating
9	Junction Box fault	photovoltaic system	Energy over loss, cable bending, Cable No clamp, Cable No welding, Rework cable, rework connector, Ribbon un proper insert.

4.3 How to prevent different faults occurred in PV system

Table 2. Standard fault prevention methods

Sr. No.	Name of fault	Prevention method
1	Line to line fault	Line to line faults are detected by using a special device known as over current protection device (OCPD)
2	Ground fault	Mersen provides PV rated fuses (10 x 38mm, 1-1/2" x 13/32") for all ground-fault protection circuits.
3	Arc Fault	Arc fault circuit interrupter (AFCI) is a standard protection device generally used against series arc fault.
4	Shading effect or Fault	There is no standard device which can detect a shading fault, But a multiple algorithm have been proposed by many researchers.
5	Hot Spots	Infrared thermography along with some other algorithms mentioned in literature.
6	Open Circuit faults	can be detected by using Earth Capacitance measurement (ECM) method as well as Line checker method
7	Blocking & bypass diode fault	Avoid partial shading on the photovoltaic module for longer period. As such no standard protection circuit is available.
7	Junction box failure	By using protection circuits such as lighting protector, string diode will be useful to avoid system over stress. Avoid unauthorized work on Connectors & cables. Ensure proper string polarity while doing the connection

V. DIFFERENT ALGORITHMS & TECHNIQUES USED FOR FAULT DETECTION & DIAGNOSIS.

This section describes the different methods used for fault detection & diagnosis in PV systems. As discussed earlier also fault diagnosis algorithms are classified into three types: visual methods, thermal methods & electrical methods out of which electrical methods are more popular as compare to rest. Electrical methods are again classified into following types:

- 1) IV characteristics analysis
- 2) Artificial intelligence method
- 3) Statistical based approach
- 4) Signal processing based approach
- 5) Based on power losses
- 6) Voltage & current measurement

5.1 IV characteristics analysis method

[6] Introduced first the method based on current voltage characteristics analysis for fault detection in photovoltaic system. This method is based on the comparison of expected vs. actual electrical parameters obtained from the current voltage characteristics. Using this method faulty disconnection in array can be found out. The important components of this method are PV node & shadow programs. This method is also applicable to obtain other faults in PV array.

Table 3. IV characteristics analysis method evaluation

Sr. No.	Ref	Type of Fault	Remark
1	[6]	Fault in array	it's a fault detection technique, easily integrated to DAS, sensors are required.
2	[3]	fault in array	easy to implement in fault detecting device, suitable for PV strings
3	[24]	fault in module	easy to implement, It is experimentally validated suitable for PV array
4	[7]	fault in module	validated experimentally, fault detection method, low cost method
5	[25]	module fault, hot spot fault, diode fault	it's a fault diagnosis method, easy for implementation, validated experimentally, suitable for medium size array
6	[26]	module & diode fault	suitable to find temporary as well as permanent fault. It's a fault diagnosis method .
7	[27]	diode & ground fault	It's a fault detection method, suitable for medium size PV array.
8	[28]	fault in module	it's a fault diagnosis method & validated experimentally with medium cost

9	[29]	fault in module	fault detection method, can be implemented easily. can be used to detect temporary or permanent fault.
---	------	-----------------	--

The nature of IV characteristics cannot always detect the presence of fault hence [30] proposed a method based on differential IV characteristics i.e. dI/dV curves, which are efficient to detect the reduction of power loss.

5.2 fault diagnosis based on artificial intelligence method

In the last few years this method is proven to its functionality in order to modelling, prediction of faults in photovoltaic systems. There are few papers available in literature based on artificial neural network & fuzzy logic used for fault diagnosis in photovoltaic system.

[31] Demonstrated the use of artificial neural network in order to detect the fault in grid connected PV system. Using this technique five different faults were identified such as power device is not working properly, fault in power device, overheating, lesser output voltage, incorrect reading of grid connected voltmeter etc. This method is also used to find out the exact location of short circuit fault in photovoltaic module [10] with a very good accuracy. It is also useful in order to monitor on line system in case of smart grid.

Potential faults in a PV system can be guess out using BBN i.e. Bayesian belief network [17]. Another method to detect faults is using Takagi Sugeno Kahn Fuzzy Rule [15]. This method is based on the difference between expected power & actual power; if the difference goes above a threshold then the fault may be predicted. Even if we got noisy data still above system recognize 90% of fault conditions.

A fault diagnosis algorithm proposed in [32] useful in order to exact locate the fault. this algorithm is useful to detect the faults such as short circuit, fault in blocking diode, fault in bypass diode of photovoltaic module. It is made up of two algorithms one is SVM i.e. hybrid support vector machine algorithm & second is k-nearest neighbour method in order to increase the percentage to exactly locate the fault. The error classification rate is low i.e. in between 0.36 to 0.55%. [33] demonstrates the diagnostic method in which identifies the avoidable increase in series resistance i.e. Rs by using fuzzy logic classifier & it is validated experimentally.

In [34] the diagnosis method was proposed in order to detect the fault in inverter. It uses the capability of current voltage characteristics. The Artificial neural network is also used to check the working of entire photovoltaic power generation system [37]. It uses ZigBee wireless sensor network. The Extension Neural network algorithm or approach is used to check whether the plant is producing output as per the expectation or not.it uses the input parameters such as solar irradiance & module temperature. It also requires the parameters like peak current, peak voltage, peak power, short circuit current, open circuit voltage etc. along with I- V characteristics. A matter element algorithm along with artificial neural network is used to build a fault diagnosis system [35].

Table 4. Comparative study is done on the fault diagnosis method based on artificial intelligence approach.

Fault detection or diagnosis.	Ref	fault detected	Remarks
Diagnosis	[31]	used to detect five faults power device is not working properly, fault in power device, overheating, lesser output voltage, incorrect reading of grid connected voltmeter	tested on small scale PV application, easy to implement as compare to other algorithms,
detection	[35]	used to detect fault in an array	Easy to implement, proposed for medium photovoltaic arrays
detection along with localisation	[10]	fault in photovoltaic array	algorithm is relatively complex, small scale plants
diagnosis	[17]	array fault , overheating , lessor output, incorrect reading etc.	complex algorithm, suitable for medium scale system
detection	[15]	it can detect fault in photovoltaic module	relatively complex, suitable for medium scale plants, cost effective
fault detection	[33]	fault in photovoltaic module	useful for temporary fault detection, medium cost, easy for implementation
fault detection & classification is possible	[32]	diode fault & module fault	fast & low computation, relatively easy for implementation
fault detection & classification is possible	[34]	module fault , overheating , lessor output, incorrect reading etc.	fast & low computation, relatively easy for implementation
detection & analysis	[36]	module fault	Tested using Matlab. Experimentally not validated

5.3 Statistical & signal processing based approach for fault detection & diagnosis in PV system

These methods basically uses the analysis of waveforms or signals .Time domain reflectometry (TDR), Earth capacitance measurement (ECM) & speared spectrum time domain reflectometry are very popular method for fault detection in photovoltaic system. In [38] time domain reflectometry is used in order to detect the location of faulty module in photovoltaic array. This method is useful to detect the fault & its location but the problem is that its performance degrades with the changes of wiring, modules, different components & installation conditions. [39,40] find the method which module is disconnected in the string based on Earth capacitance measurement & time domain reflectometry. TDR is used to detect where the degradation is happening such as increase in series resistance between the Photovoltaics. [40] Successfully demonstrated ECM method application for amorphous silicon photovoltaic modules along with crystalline silicon modules.[41,42] proposed a time domain reflectometry technique for breakages in circuit, defects in insulation, reverse polarities etc. [43,44] proposes a system consists of a frequency response analyser in order to measure radio frequency propagation though arrays of difference light intensities. [45] Proposes a system which is used to find arc fault consist an AF circuit protection method. The arc fault can be detected resulting from non-working of system components.

Table 5. Comparative study is done for statistical & signal processing based approach

Fault detection or diagnosis.	Ref	fault detected	Remarks
fault diagnosis	[41,42]	Array faults & line to line faults	tested on large size PV plants, Time domain reflectometry equipment is necessary
fault detection & localisation	[38]	module fault	power conditioners with possible integration, applicable for medium size PV string
fault detection & localisation	[39,40]	module fault	Easy implementation, applicable for medium size PV string
Fault detection	[43,44]	Array fault	suitable for PV module, medium cost is required.
Detection	[45]	Array fault	Easy to implement, suitable for PV array

5.4 Algorithms based on power loss analysis

The theory of power loss in photovoltaic system identifies three different groups of faults& the false alarms [19]. The faults are fault in particular module of string, fault in particular string, ageing effect, MPPT error, partial shadowing error, ageing effect etc. Four factors have been established by International Energy agency (IEA) photovoltaic power system program & they are reference yield, array yield, final yield & performance ratio. The power ratio is of following types: capture losses, system losses, thermal capture losses & miscellaneous capture losses. Using losses we can detect whether the fault is occurred or not & by using performance ratio i.e. current ratio & voltage ratio we can detect a particular faults & its location. A fault detection & diagnosis technique is developed by [46] using MATLAB/ SIMULINK. It compares the electrical parameters such as Voc, Isc, Pm etc. to detect possible faults in photovoltaic system. Climatic condition of actual site are considered in order to set the threshold.

5.4 Algorithms based on Voltage current measurements

[47] Proposed a learning model use to detect a fault in photovoltaic system. Here they have proposed a graph based semi supervised learning model which is useful to detect line to line fault & open circuit fault.

Arduino board based hardware device has been developed by [48] used for mismatch identification of solar cells. Voltage, temperature & resistance of module is measured & taken into consideration. This method is used to find the mismatch fault.

VI. Challenges

New faults are emerging day by day; they may create a major problem as they are still undetected. Overall there is a continuous need to develop new techniques & improvement is required in existing techniques especially in equivalent model of PV cell. Recently two diode equivalent model is proposed instead of single diode equivalent model, on which more work is yet to be one.

- Most of the Experimental work done is a system specific. A generalized algorithm may be develop for fault detection & diagnosis.
- The current systems developed are only for detection of two or three faults at a time. An integrated system can be develop which can detect multiple faults.
- Many algorithms are justified theoretically, so they can be verified experimentally.
- Simple & cost effective system can be develop, so these systems can be utilized for the monitoring & supervising of small PV System & Power plants.
- Processing time for fault detection or execution time required to detect a particular fault is still an area for research.

VII. Conclusion

In this paper the overview of different faults occurred in photovoltaic system are reviewed. The different methods, models available in literature to estimate the output power of PV cell are thoroughly reviewed. Different generalized & customized softwares are available for simulation of their models along with MATLAB/SIMULINK. Along with this, overview of different techniques/algorithm/methods available for fault detection & diagnosis for photovoltaic system are studied in details & in comparative manner. In order to increase the effectiveness, reliability of a PV system a strong fault diagnosis technique is must. The technique should respond to the fault in a quick manner with good accuracy & many algorithms in literature addresses this concern.

Electrical methods used for fault diagnosis are more suitable for large scale power plants while the visual methods such as thermal inspection, visual inspection are more suitable for small scale plants. Artificial intelligence based methods are more complex in terms of logic building but they reduce the efforts & cost of system. The diagnosis methods using power losses are also requires less hardware. They addresses many faults occurred in PV system.

Online fault detection is an area which is still neglected. The investment cost to develop a supervisory & monitoring system is still very high, so it is very difficult to accommodate small power plants into it. Single system addresses one or two faults only. Critical faults such as faults due to Major delamination are not address yet.

References

- [1]. Rumery S., Holm A., O'Brien K. & Baca J., U.S. Solar Market Insight, Wood Mackenzie Limited and the Solar Energy Industries Association (SEIA), USA, 2017
- [2]. Firth S.K., Lomas K.J. & Rees S.J., "A simple model of PV system performance and its use in Fault detection", *Solar Energy Materials & Solar Cells*, vol. 84, pp. 624-635, 2010
- [3]. Chao K.H., Ho S.H. & Wang M.H. , "Modelling and fault diagnosis of a photovoltaic system", *Electric Power system Research*, vol. 78, pp. 97-105, 2008
- [4]. Guash D., Silvestre S., Calatayud R., "Automatic failure detection in photovoltaic systems", in *Proceedings of the 3rd world conference on photovoltaic energy conversion*, Osaka, Japan, 2003.
- [5]. Hamdaoui M, Rabhi A, Hajjaji A, Rahmoum M, Azizi M., "Monitoring and control of the performances for photovoltaic systems", in *International renewable energy congress*, Sousse, Tunisia; 2009.
- [6]. Stellbogen D., "Use of PV circuit simulation for fault detection in PV array fields", in *Conference of the Twenty Third IEEE Photovoltaic Specialists*, pp. 1302-1307, 1993
- [7]. Gokmen N.A., Karatepe E. & Celik B., "Simple diagnostic approach for determining of faulted PV Modules in string based PV arrays", *Solar Energy Materials & Solar Cells*, vol.86, pp.3364-3377, 2012
- [8]. Platon R., Martel J. & Norris W. N. , "Online Fault detection in PV Systems", *IEEE Transaction on Sustainable energy*, Vol. 6, pp.1200-1207, 2015
- [9]. Ando B., Bagalio A., Pistorio A., " Sentinella: smart monitoring of photovoltaic systems at panel level", *IEEE Transaction on Instrumentation & Measurement* 64(8), 2188-99, 2015
- [10]. Syafaruddin, Karatepe E. & Chen H.T., "Controlling of Artificial Neural Network for Fault Diagnosis of Photovoltaic Array", In *the Proceedings of the 16th International Conference on Intelligent System Application to Power Systems (ISAP)*, Crete, Greece, 2011
- [11]. Riley D. & Johnson J., "Photovoltaic Prognostics and Heath Management using Learning Algorithms", In *the proceedings of 38th IEEE Photovoltaic Specialists Conference* , Austin, Texas, 2012
- [12]. Mekki H., Mellit A., Salhi H, Guessoum A. "Artificial neural network-based modeling and simulation" *Mediterranean Journal of Modelling & simulation*, MJMS 03,001-009, 2015.
- [13]. Akram M. N., Lotfifard S., " Modeling and health monitoring of DC side of photovoltaic array" , *IEEE Transaction on Sustainable Energy*, vol.6, issue 4, 1245-53, 2015
- [14]. Cheng Z., Zhong D., Li B. & Yanli L., "Research on fault detection of PV array based on data fusion and Fuzzy mathematics", In *the Proceedings of the Power and Energy Engineering Conference*, Wuhan, China, 2011
- [15]. Ducange P., Fazzolari M., Lazzarini B. & Marcelloni F., "An Intelligent System for Detecting Faults in Photovoltaic Fields", In *the proceedings of 11th International Conference on Intelligent Systems Design and Applications*, Cordoba, Spain, 2011
- [16]. Bonsignore L., Davarifar M., Rabhi A., Giuseppe M.T. & Elhajjaji A. , "Neuro-Fuzzy fault detection method for photovoltaic systems" *6th International Conference on Sustainability in Energy and Buildings*, Cardiff, Wales, UK, 2014
- [17]. Coleman A. ,Zalewski J., "Intelligent fault detection and diagnostics in solar plants, in *IEEE Proceedings of the 6th International Conference on Intelligent Data Acquisition and Advanced Computing Systems*; 2011.
- [18]. Wang M.H., Chen M.J., "Two-stage fault diagnosis method based on the extension theory for PV power systems", *International Journal of Phototenergy*, volume 2012, 2012
- [19]. Chouder A. & Silvestre S. , "Automatic supervision and fault detection of PV systems based on power losses analysis", *Energy Conversion and Management*, vol.51, pp. 29-37, 2010
- [20]. Mohamed H.A., Rabhia A., Ahmed E., & Giuseppe M. T., "Real Time Fault Detection in Photovoltaic Systems" In *the proceedings of 8th International Conference on Sustainability in Energy and Buildings*, Turin, Italy, 2016
- [21]. Lahiani A.T., Abdelghania A. B. & Belkhodja I.S. , "Fault detection and monitoring systems for photovoltaic installations: A review" , *Renewable and Sustainable Energy Reviews*, Volume 82, 2017
- [22]. Kuitche J. M., Pan R. & TamizhMani G., "Investigation of dominant failure modes for field-aged crystalline PV modules under desert climatic conditions", *IEEE Journal of Photovoltaics*, vol. 4, pp. 814-826, 2014
- [23]. Jordan D.C., Silverman T.J., Wohlgenuth J.H., Kurtz S.R. & Vansant K.T., "Photovoltaic failure and degradation modes", *Progress in Photovoltaics: Research and Applications*, vol. 25, pp. 318-326, 2017
- [24]. Kaplanis S, Kaplani E. "Energy performance and degradation over 20 years performance of BP c-Si PV modules" *Simulation Model Practical Theory* 19(4),1201-11, 2011
- [25]. Tina G.M., Cosentino F., Ventura C., "Monitoring and diagnostics of photovoltaic power plants", In: Sayigh A., editor. *Renewable Energy in the Service of Mankind*, Vol II. Cham: Springer, pp. 505-16, 2016

- [26]. Chine W., Mellit A., Pavan A.M., Lughì V., "Fault diagnosis in photovoltaic arrays", In Proceedings of the IEEE International Conference on Clean Electrical Power (ICCEP), pp. 67–72, 2015
- [27]. Fezzani A., Mahammed I.H., Drid S., Chrifi-alaoui L., "Modeling and analysis of the photovoltaic array faults", In Proceedings of the 3rd IEEE International Conference on Control, Engineering & Information Technology (CEIT), pp. 1–9, 2015
- [28]. Wang W, Liu AC-F., Chung HS-H., Lau RW-H., Zhang J., Lo AW-L., "Fault diagnosis of photovoltaic panels using dynamic current–voltage characteristics", IEEE Transaction on Power Electronics, pp.1588–99, 2016
- [29]. Hachana O., Tina G. M., Hemsas K.E., "PV array fault Diagnostic Technique for BIPV systems", Energy & Buildings, pp.263–74, 2016
- [30]. Miwa M, Yamanaka S, Kawamura H, Ohno H, Kawamura H. "Diagnosis of a power output lowering of PV ARRAY with a (-dI/dV)-V characteristic", In Proceedings of the IEEE 4th World Conference on Photovoltaic Energy Conference, pp.2442–45, 2006
- [31]. Wu Y, Lan Q, Sun Y , "Application of BP neural network fault diagnosis in solar photovoltaic system", In International Conference of Mechatronics & Automation, ICMA, 2009
- [32]. Rezgui W, Mouss L-H, Mouss NK, Mouss MD, Benbouzid M., "A smart algorithm for the diagnosis of short-circuit faults in a photovoltaic generator", In Proceedings of the First International Conference on Green Energy ICGE, pp. 139-43, 2014
- [33]. Spataru S, Sera D, Kerekes T, Teodorescu R., "Detection of increased series losses in PV arrays using Fuzzy Inference Systems", In Proceedings of the 38th IEEE Photovoltaic Specialists Conference (PVSC), pp.464-69, 2012.
- [34]. Spataru S, Sera D, Kerekes T, Teodorescu R., "Diagnostic method for photovoltaic systems based on light I–V measurements", Solar Energy 119 ,pp. 29–44.,2015
- [35]. Chao K-H, Chen C-T, Wang M-H, Wu C-F., "A novel fault diagnosis method based-on modified neural networks for photovoltaic systems", Advances in Swarm Intelligence, Springer, p p. 531–9, 2010
- [36]. Mohamed A, Nassar A., "New algorithm for fault diagnosis of photovoltaic energy systems", International Journal of Computer Application,114, 2015
- [37]. Chao K. H, Chen P. Y, Wang M. H, Chen C. T., "An intelligent fault detection method of a photovoltaic module array using wireless sensor networks", International Journal of Distributed Sensor Networks, 2014.
- [38]. Takashima T, Yamaguchi J, Otani K, Kato K, Ishida M. Experimental Studies of Failure Detection Methods in PV Module Strings, in IEEE Proceedings of the 4th World Conference on Photovoltaic Energy Conversion, 2006.
- [39]. Takashima T., Yamaguchi J., Otani K., Oozeki T., Kato K. & Ishida M. , "Experimental studies of fault location in PV module strings" Solar Energy Materials & Solar Cells, vol. 93, pp. 1079–1082 , 2009
- [40]. Takashima T, Yamaguchi J, Ishida M., " Disconnection detection using earth capacitance measurement in photovoltaic module string", Progress in Photovoltaic: Research & Applications, 16, pp.669–77,2008
- [41]. Schirone L, Califano F, Moschella U, Rocca U, "Fault finding in a 1 MW photovoltaic plant by reflectometry", In Proceedings of the 24th IEEE Photovoltaic Specialist on Energy Conversion, pp. 846–9, 1994
- [42]. Schirone L, Califano F, Pastena M., " Fault detection in a photovoltaic plant by time domain reflectometry" , Progress in Photovoltaic: Research & Applications, 2, pp.35–44, 1994
- [43]. Johnson J, Kuzmaul S, Bower W, Schoenwald D., "Using PV Module and Line Frequency Response Data to Create Robust Arc Fault Detectors", In Proceedings of the 26th European Photovoltaic Solar Energy Conference and Exhibition Hamburg, Germany, pp. 3745–50,2011
- [44]. Johnson J, Pahl B, Luebke C, Pier T, Miller T, Strauch J, Kuzmaul S, Bower W., " Photovoltaic DC Arc Fault Detector testing at Sandia National Laboratories", In Proceedings of the 37th IEEE Photovoltaic Specialists Conference (PVSC), pp.3614–19, 2011
- [45]. Dini D A, Brazis P W, Yen K H., " Development of arc-fault circuit-interrupter requirements for photovoltaic systems", In Proceedings of the Photovoltaic Specialists Conference (PVSC), 37th IEEE, pp. 1790–94, 2011
- [46]. Houssein A, Heraud N, Souleiman I, Pellet G., "Monitoring and fault diagnosis of photovoltaic panels. In: Proceedings of the IEEE International Energy Conference and Exhibition, pp. 389–94,2010
- [47]. Ye Z, Ball R, Mosesian J, de Palma J F, Lehman B., "Graph-based semi-supervised learning for fault detection and classification in solar photovoltaic arrays", IEEE Transaction on Power Electronics, 30, pp. 2848–58, 2015
- [48]. Mahendran M, Anandharaj V, Vijayavel K, Winston D.P. "Permanent mismatch fault identification of photovoltaic cells using arduino", ICTACT Journal on Microelectronics, pp. 79–82.
- [49]. Electrical Installations of Buildings—Part 7: requirements for special installations or locations—section 712: solar PV power supply systems, IEC Standard 60364-7-712, 2002.
- [50]. Installation and safety requirements for PV generators, IEC Standard 62548.
- [51]. Article 690 in solar photovoltaic systems of national electrical code, NFPA70, 2011.
- [52]. Johnson J, Oberhauser C, Montoya M, Fresquez A, Gonzalez S, Patel A., "Crosstalk nuisance trip testing of photovoltaic DC arc-fault detectors", In Proceeding of the 38th photovoltaic specialists conference (PVSC). IEEE, pp. 001383–7, 2012
- [53]. Johnson J, Kang J Arc-fault detector algorithm evaluation method utilizing pre-recorded arcing signatures. In: Proceeding of the 38th photovoltaic specialists conference (PVSC). IEEE; 3 Jun 2012. p. 001378–82.
- [54]. Dhanup S. Pillai, N.Rajasekar, "A comprehensive review on protection challenges and fault diagnosis in PV systems", Renewable and Sustainable Energy Reviews, 91, pp. 18-40, 2018
- [55]. A. Mellit, G.M. Tina, S.A. Kalogirou, "Fault detection & diagnosis methods for photovoltaic systems: A review", Renewable and Sustainable Energy Reviews, 91, pp. 1-17, 2018
- [56]. Zhao Y, Lyons Jr R., "Ground-fault analysis and protection in PV arrays", Procedure Photovoltaic topic Protection note 1, Issue 1, pp. 1–4., 2011
- [57]. M. Cotterell, "Installation guidelines: electrical", In Practical Hand book of Photovoltaics, 2nd edition Boston. MA, USA: Academic, 2012, Ch. IIC-3. p. 819–34
- [58]. Armijo KM, Johnson J., "Characterizing fire danger from low power PV arc-faults", Albuquerque, NM (United States): Sandia National Laboratories (SNL-NM), 2014.
- [59]. Simon M, Meyer EL., "Detection and analysis of hot-spot formation in solar cells", Solar Energy Materials & Solar Cells 94:106–13,2010
- [60]. Chang M, Chen C, Hsueh C, Hsieh W, Yen E, Ho K., "The reliability investigation of PV junction box based on 1GW worldwide field database", In Proceedings of the 42nd IEEE Photovoltaic Specialist Conference (PVSC)., pp. 1–4, 2015
- [61]. Kato K., "PV module failures observed in the field- solder bond and bypass diode failures", 2015.
- [62]. Ancuta F. & Cepisca C., "Fault Analysis Possibilities for PV Panels", In the Proceedings of 3rd International Youth Conference Energetics (IYCE), Leiria, Portugal,2011

- [63]. Chouder A. & Silvestre S., "Modelling and simulation of a grid connected PV system based on the evaluation of main PV module parameters", *Simulation Modelling Practice and Theory*, vol.20, pp.46-58,2012
- [64]. Chouder A., Silvestre S.& Karatepe E., "Automatic fault detection in grid connected PV systems", *Journal on Solar Energy*, vol.94, pp. 119-127,2013
- [65]. Gonzalez R.B., Bacha S. & Long B., "Fault diagnosis in a grid-connected photovoltaic system by Applying a signal approach", In the Proceedings of the 37th Annual Conference on IEEE Industrial -Electronics Society, Melbourne, Australia,2011

IOSR Journal of Electronics and Communication Engineering (IOSR-JECE) is UGC approved Journal with Sl. No. 5016, Journal no. 49082.

Pramod Sonawane. " A Comprehensive Review of Fault Detection & Diagnosis in Photovoltaic Systems." *IOSR Journal of Electronics and Communication Engineering (IOSR-JECE)* 14.3 (2019): 31-43